



ALL TITANIUM

FLOWLINE

The Vulcan Flowline electric pool heater, with simple analogue control and silent operation is the ideal solution for any private/residential pool or spa. Designed by engineers with over 80 years of combined experience, this popular electric heater boasts all of the craftsmanship and stringent quality standards you would expect from a British manufacturing company - Reliability, durability, safety and efficiency.



FEATURES

- 8 models available, ranging from 2-kW to 24-kW
- Non-wired. Requires connection to external contactor
- Robust, durable construction and compact design
- Ultra-reliable flow switch for safe operation
- Fitted with temperature thermostat and overheating sensor
- Analogue control with 1.2°C differential
- Titanium flow tube and titanium heating element(s)
- Vortex, long life, stay clean heating element technology
- 100% efficiency throughout the product life
- Sea and salt chlorinated water compatible
- Can be floor or vertically wall mounted
- Silent operation

SYSTEM SETUP

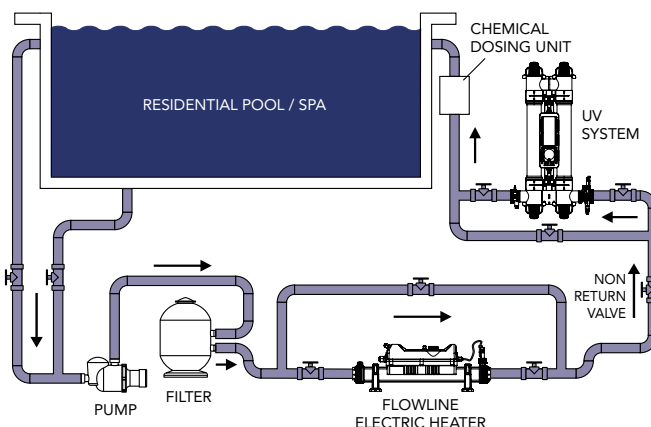

TECHNICAL DRAWINGS

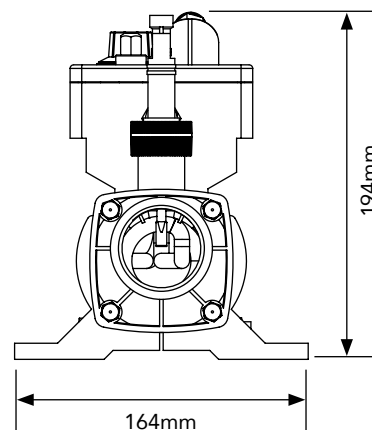
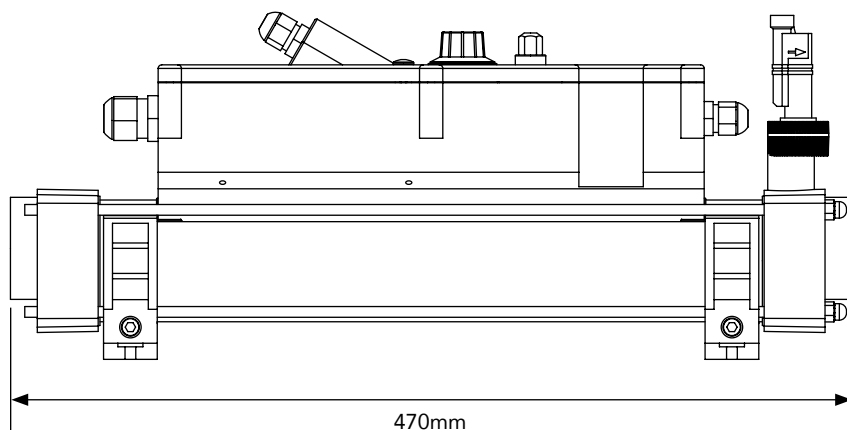

SPECIFICATIONS

Power supply:	Single phase or 3-Phase	Seals:	High temperature special formula EPDM ferrules. TPE end fitting gaskets
Min. flow rate:	2-kW to 6-kW: 1m ³ /h 9-kW to 24-kW: 4m ³ /h	Water connections:	1½" BSP female thread supplied with 1½"/50mm stepped PVC unions for rigid pipe and 1½"/1¼" stepped hose tails for flexible pipe
Max. flow rate:	17m ³ /h	Ingress protection rating:	IP44
Heating element:	Grade 1 titanium	Frequency:	50/60 Hz
Flow tube:	Grade 1 titanium	Working pressure:	4 bar maximum
Control thermostat:	Analogue: 0 > 45°C 1.2°C differential	Mounting:	Floor or wall mounting
Safety thermal cut out:	60°C (manual reset)		
Flow switch:	Rhodium tipped reed switch with titanium fulcrum pin		

MODELS

MODEL	POWER OUTPUT	LOAD (amp)	LENGTH (mm)	NET WEIGHT (kg)	GROSS WEIGHT (kg)	VOLUME (m ³)	PRODUCT CODE
220-240V 1-Phase	2-kW	8.5	462	2.936	4.230	0.046	V-T82B
	3-kW	13	462	2.936	4.230	0.046	V-T83B
	6-kW	26	462	2.936	4.230	0.046	V-T86B
	9-kW	40	462	3.236	4.530	0.046	V-T89B
400V 3-Phase*	6-kW	9	592	3.656	4.950	0.046	V-T36B
	9-kW	13	592	3.656	4.950	0.046	V-T39B
	12-kW	18	592	3.656	4.950	0.046	V-T3AB
	15-kW	22	592	3.656	4.950	0.046	V-T3BB
	18-kW	26	592	3.656	4.950	0.046	V-T3CB
	24-kW	34	592	3.656	4.950	0.046	V-T3DB
220~240V 3-Phase	6-kW	15	592	3.726	5.020	0.046	V-T36B-D
	9-kW	23	592	3.726	5.020	0.046	V-T39B-D
	12-kW	30	592	3.726	5.020	0.046	V-T3AB-D
	15-kW	38	592	3.726	5.020	0.046	V-T3BB-D
	18-kW	46	592	3.726	5.020	0.046	V-T3CB-D

*For voltages other than 400V please add: -380 or -415 at the end of the product code e.g. V-T36B-380

PRESSURE DROP

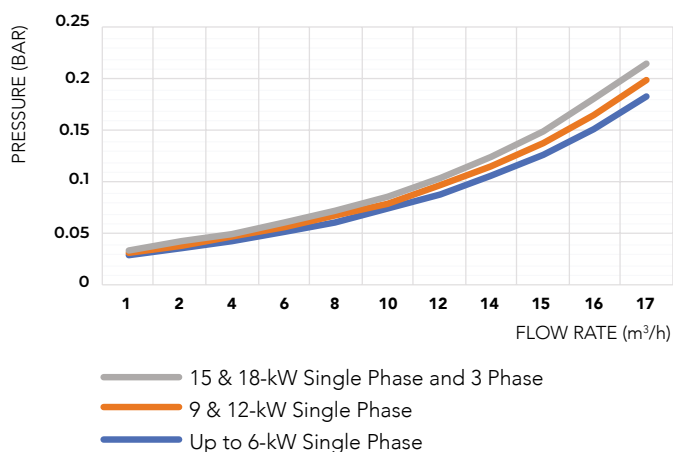

KEY PARTS

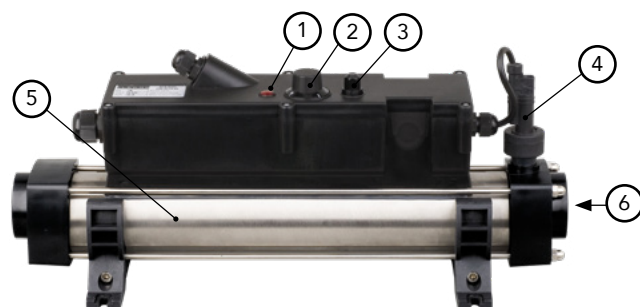

- 1 Heater 'ON' indicator
- 2 Temperature set dial
- 3 Thermal safety cut-out reset switch
- 4 Flow switch
- 5 Titanium flow tube
- 6 Titanium heating element/s (internal)